

Easy and Efficient Transformer : Scalable Inference Solution For large NLP model

Gongzheng Li*, Yadong Xi*, Jingzhen Ding, Duan Wang, Bai Liu, Changjie Fan, Xiaoxi Mao, Zeng Zhao†

Fuxi AI Lab, NetEase Inc., Hangzhou, China

{ligongzheng, xiyadong, dingjingzhen, wangduan, hzliubai, fanchangjie, maoxiaoxi, hzzhaozeng}@corp.netease.com

Abstract

Recently, large-scale transformer-based models have been proven to be effective over a variety of tasks across many domains. Nevertheless, putting them into production is very expensive, requiring comprehensive optimization techniques to reduce inference costs. This paper introduces a series of transformer inference optimization techniques that are both in algorithm level and hardware level. These techniques include a pre-padding decoding mechanism that improves token parallelism for text generation, and highly optimized kernels designed for very long input length and large hidden size. On this basis, we propose a transformer inference acceleration library – Easy and Efficient Transformer (EET), which has a significant performance improvement over existing libraries. Compared to Faster Transformer v4.0’s implementation for GPT-2 layer on A100, EET achieves a 1.5-4.5x state-of-art speedup varying with different context lengths. EET is available at <https://github.com/NetEase-FuXi/EET>. A demo video is available at <https://youtu.be/22UPcNGcErg>.

1 Introduction

In recent years, Transformer-based models have achieved impressive results in multiple domains including natural language processing(NLP)(Vaswani et al., 2017)(Devlin et al., 2019) (Raffel et al., 2020) (Brown et al., 2020), computer vision (Jiang et al., 2021) (Dosovitskiy et al., 2020) and speech processing(Baevski et al., 2020)(Baevski et al., 2021) etc. Kaplan etc.(Kaplan et al., 2020) proposed the scaling law which argues that the loss of a neural language model "scales as a power-law with model size, dataset sizes, and the amount of compute used for training". The scaling law has been empirically supported by multiple

following works(Brown et al., 2020)(Zhai et al., 2021).

However, despite the high performance achieved by mega-sized models, they are notoriously time-consuming and costly to train. Even the deployment requires extensive hardwares, undermining the democratization of deep learning. For example, a GPT-2 medium sized model takes about 10s to make inference with on an RTX 2080ti.

There are multiple approaches to improving the inference efficiency, including knowledge distillation(Hinton et al., 2015), model pruning(Voita et al., 2019), quantization(Shen et al., 2019), etc. Despite these efforts, optimizing the CUDA implementation of transformer layer for better utilization of hardware has been paid a lot of attention due to its orthogonality with respect to previously mentioned approaches. Previous works include Nvidia’s Tensorrt(NVIDIA, 2021b) and Faster Transformer(FT)(NVIDIA, 2021a), Bytedance’s Lightseq(Wang et al., 2021). They have implemented multiple optimization techniques including kernels fusion, gemm optimization, quantization, etc,. However, there still exist several issues. For example, they are not effective enough at fully exploiting the parallelism of the input sequence, which leads to inefficient utilization of GPU computing power; some of them could not support hidden size and sequence length above 1024; besides, applying them into real applications is also non-trivial.

In this paper, we propose a novel transformer inference acceleration library designed for PyTorch(Paszke et al., 2019), the Easy and Efficient Transformer(EET). In EET, we implement a bunch of optimization techniques. Firstly, we propose to use pre-padding for sequence padding. Pre-padding makes the input context and the decoded token have the correct relative position, consistent with the pre-training setting, which also simplifies the engineering implementation for the parallel

* Equal contribution

† Corresponding Author

inference of the context and incremental decoding for the generated tokens. Secondly, we implement custom CUDA kernels to avoid explicit matrix multiplications of attention masking and attention weights. Finally, we extend all kernels to support a larger hidden size and longer context length which could be above 1024.

Deploying a PyTorch model with TensorRT or Faster Transformer is sophisticated. We simplify the deployment workflow with EET. EET provides Python-level APIs, no need to convert models to ONNX or other formats any more. It also integrates a python web server to improve the service capability with some important features including dynamic batching, variable-input length, reordered incremental state, early stop, which further facilitates the deployment.

2 Pre-Padding Decoding

2.1 Incremental Decoding

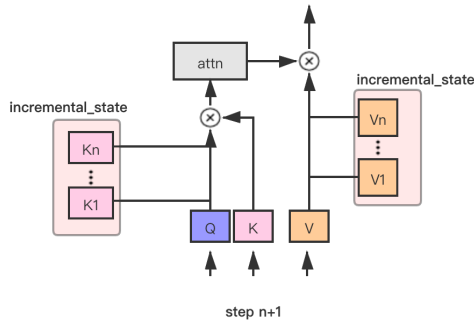

Figure 1: Incremental decoding

Incremental decoding implemented in Fairseq is to solve the efficiency problem in auto-regressive generation. As seen in the Figure 1, the key idea is to use a dictionary of incremental_state to save keys and values produced in the previous step inside the decoder, while incremental_state will participate in the computation of masked self-attention in the successive step, avoiding duplicated computation.

2.2 Pre-padding Decoding

Tokens in the sequences is processed one after one. Incremental decoding regards them as predicted, which means that the count of total decoding is equal to the max sequence length, irrelevant with other sequences

$$N_{step} = max_seq_len$$

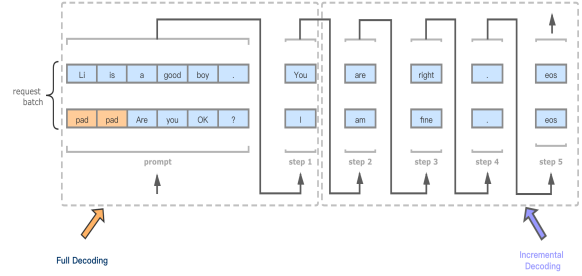

Figure 2: Pre-padding decoding

The sequences in the batch could be processed concurrently similar to the teacher forcing in the training phase. A simple idea is to take the sequences as a whole input vector fed into the network with a sequence mask. Keys and values for each token in sequences were saved for afterward incremental decoding. The number of decoding step is :

$$N_{step} = 1 + (max_seq_len - prompt_len)$$

However, this is not enough with different sequence lengths in a batch, and an extra padding process needs to be applied. Padding from right side will cause a relative position shift problem upon generated tokens, which must handle carefully. We instead ensure the relative position by padding from the left side. After that, we pack all the sequences into a batch, as seen in Figure 2.

We implement pre-padding decoding by modifying Fairseq and compare it with the vanilla incremental decoding, as seen in Figure 3. A obvious gain could be obtained through the parallel processing through sequences.

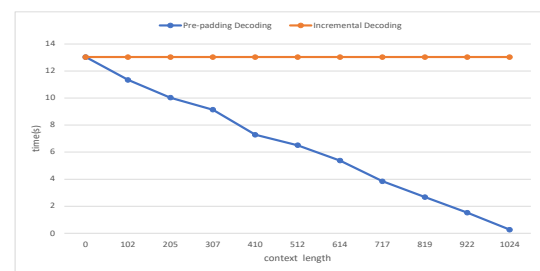

Figure 3: Compare between pre-padding decoding and incremental decoding

In the recent work of FT, it also includes this technique for transformer decoder(GPT-2), but a key difference from EET is that the inference context length depends on the minimum sequence length instead of maximum sequence length in the batch, which means EET could take better usage of

the parallelism of the context than FT and achieve a higher performance.

3 High Performance Kernels

Faster Transformer developed by Nvidia implemented highly optimized CUDA kernels for transformer inference. We design our custom kernels basing on the implementation of FT, making further optimization with considerations below:

1. Padding tokens have no effect on the final results. Avoiding the participation of padded tokens in multi-head attention computation, instead of simply using padding masks, could greatly reduce the computational overhead at inference.
2. Sequence mask is necessary for accurate calculation of multi-head attention output results. However, constructing the mask occasionally as context length changes is also very time-consuming.
3. To support model size and sequence length beyond 1024, FT reassigns the task with multi-block on an fixed dimension sizes(128, 256, 384, 512), which may cause thread-level parallelism degradation.

We firstly design kernels to deprecate the sequence mask which requires time-consuming construction and device memory occupancy. Then we fuse the padding mask to save the unnecessary computation for padding tokens. The avoidance of the two masks not only improves the performance but also makes it easier to implement the pre-padding decoding. Finally we break the CUDA thread number limitation of 1024 and extend the kernels by Thread-block-folding, thus supporting the hidden size smaller than 16384 and sequence length smaller than 4096.

3.1 Mask Fusion

Like kernel fusion, mask fusion integrates the mask into the kernels, no longer storing any explicit functional parameter of the mask and avoiding matrix multiplication between mask and attention weights. Each thread or block in CUDA will map a token's data in multi-head attention's calculation one by one when we design the kernels. Sequence mask fusion could be achieved by assigning a -inf value to attention representation when the CUDA position of the query token being processed is larger

than the CUDA position of the key token. Padded token's computation could be avoided by starting or ending the loop from the padding offset according to pre-padding or post-padding. When the block sequentially processes each token. Here we show the pseudocode, and the C++ code could be found in our open-source repository(EET).

Algorithm 1 GPT2 attention's Softmax for context

```
1: Input: Q * K result, padding Length
2: Outpt: attention
3: set Block=(seqLen)
4: set grid=(batch*headNum)
5: set batchId=blockIdx.x/headNum
6: set qkOffset=blockIdx.x*seqLen*seqLen
7: qkOffset+= padLen*seqLen
8: pad calculation is avoid here
9: for i = padLen; i<seqLen; i++ do
10:   tmp = qkBuffer[threadIdx.x+qkOffset]
11:   tmp *= scalar
12:   sequence mask is achieved here
13:   if threadIdx.x not in (padLen, i) then
14:     tmp = -inf
15:   end if
16:   maxVal=blockReduceMax(tmp)
17:   if threadIdx==0 then
18:     MaxS=maxVal
19:   end if
20:   qk=expf(tmp-MaxS)
21:   SumS=blockReduceSum(qk)
22:   if threadIdx.x==0 then
23:     SumS=SumS+1e-6f
24:   end if
25:   qkBuffer[threadIdx.x+qkOffset]=qk/SumS
26:   qkOffset+=seqLen
27: end for
```

3.2 Thread Block Folding

In recent research works, most state-of-art transformer-based models have sizes that are greater than 1024. However, considering the CUDA block only supports a maximum thread number of 1024, FT v3.1 implemented kernels that limited the hidden size and sequence length up to 1024, causing limited usability in many cases. To break this limit, FT v4.0 directly specifies the number of threads in a block basing on the model hidden size, including 128, 256, 384, or 512, and then assigns multiple blocks to the task. For example, assuming the model dimension is 1280, and we specify the 128 as the threads number in a block, so

10 blocks for a model hidden representation will be created. In some cases, this straightforward method will cause serious performance degradation as there are may not enough threads in one block, especially set to 128 or 256.

We propose a Thread-Block-Folding approach to upgrade all kernels in FT, enabling them to support larger hidden sizes and longer sequence lengths. This approach allows us to extend any kernel to any model size and any sequence length with minimum changes as well as non-degraded performance.

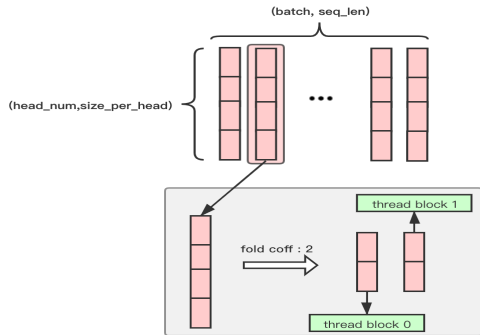

Figure 4: Thread block folding

Taking hidden size expansion as an example, the core point of the Thread-Block-Folding approach is to keep the (batch, seq_len) dimension task assignment unchanged over the grid and to redesign multiple blocks corresponding to (head_num, size_per_head) dimension task assignment. See figure 4. When head_num * size_per_head tasks could not be held by one block, they would be folded in half and assigned into another new threads block. If the two blocks still could not handle all the data tasks, then fold it again until all the data tasks can be assigned into the blocks. A folder coefficient is introduced here to characterize the number of folding times related to model size.

$$fold_coeff = 2^{\lceil \frac{model_size}{1024} \rceil - 1}$$

To give an example, assuming the model size is 1280, we fold it in half and create another block for it, so the 1280 data would be assigned into 2 blocks with 640 threads in every block. the fold_coeff is set to 2.

We use NT to represent the numbers of threads in a block, expressed by the following formula. Then we can deduce that the minimum NT is 512 when model_size is larger than 1024, beneficial for

GPU task scheduling, making the most of thread-parallelism.

$$NT(model_size) = \frac{model_size}{2^{fold_coeff}}$$

4 Using EET

Integrating EET in an existing project and deploying a web API service with EET is very convenient. EET provides APIs both on op-level and model-level, which give users much flexibility to model customization. EET also includes an out-of-the-box web service with dynamic batching.

4.1 Op-level and model-level APIs

EET provides two levels of APIs, Operator level and model level, as in Table 1.

Users could customize models if needed with the APIs provided, and adjust their models according to the API's parameters. This allows for a more flexible model definition. What's more, EET could be easily integrated into existing Fairseq and transformers projects by simply replacing several specified files in the last frameworks. Then users could enjoy the speedup brought by EET without any code changes, not to mention the hassle of model conversion.

model APIs	GPT-2 Bert
operator APIs	embedding layer-norm multi-head-attention cross-multi-head-attention ffn

Table 1: model-level and op-level APIs

4.2 Dynamic batching

Dynamic batching is a very important way to increase the throughput of a deployed online service by merging multiple client requests into one batch and doing inference in parallel. EET implements three key features to make it available:

1. Variable batch size. EET sets a maximum batch size and allocates all the GPU memory in advance, allowing every batch size smaller than the maximum batch size at runtime.
2. Variable input length. To merge different requests into a single batch, EET sets a

maximum sequence length and allocates all the GPU memory in advance likewise, then padding the input sequences from left side.

3. Early stop. At generation, some of input sequences would be finished early. EET supports reordering incremental state and avoids some of the sequences in the batch to continue occupying computational resources after they reach their finish.

EET includes a ready-made python middleware, the Service-Streamer(ShannonAI, 2021), to provide dynamic batching-enabled web service. Deploying a web API service with EET is much more convenient than with Tensorrt and Triton¹ that requires a complex workflow, as seen in Figure 5.

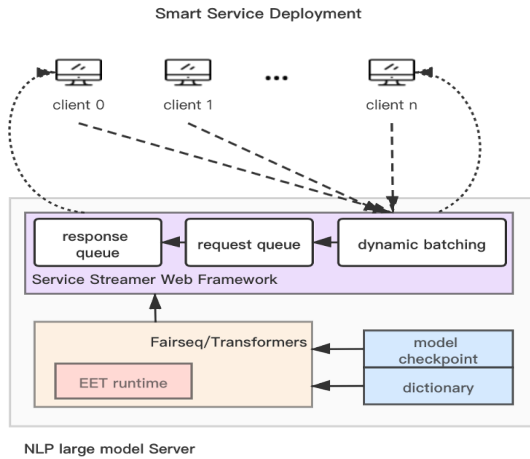

Figure 5: NLP large model Server

5 Experiments

5.1 GPT-2 layer on A100 and 3090

We tested the performance of inference for GPT-2 layer using EET on A100 and 2080ti, comparing it with Fairseq and Fast Transformer. We designed two sets of experiments: 1) Firstly test the speedup with different context lengths; 2) Secondly test the speedup with different hidden sizes.

5.1.1 Inference performance at different decoding lengths

The configuration is as table 2 and 3.

¹<https://developer.nvidia.com/nvidia-triton-inference-server>

batch size	4
hidden size	1024
maximum context length	1024
precision	fp16

Table 2: Configuration for performance with different decoding length compared to Fairseq and Faster Transformer(v3.1)

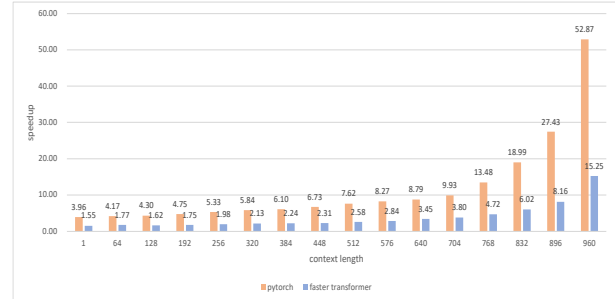

Figure 6: Inference speedup of EET with different context lengths on A100 compared to Fairseq and Faster Transformer(v3.1)

batch size	8
hidden size	2048
maximum context length	1024
precision	fp16

Table 3: Configuration for performance with different decoding length compared to Faster Transformer(v4.0)

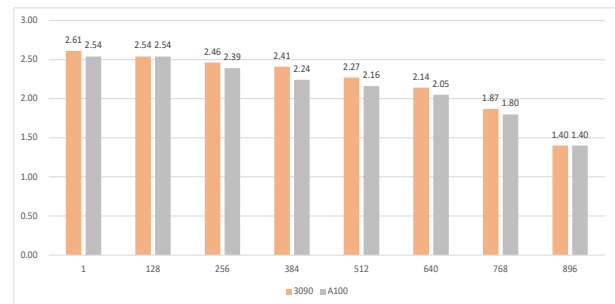

Figure 7: Inference speedup of EET with different context lengths on A100 and 3090 compared to Faster Transformer(v4.0)

The speedup increases as the context length increases. This is because in EET, explicit calculation of sequence mask is deprecated. What's more, EET has further optimizations. For example, some cublas handles are created at the initialization time while Faster Transformer(v4.0) do it at runtime.

5.1.2 Performance with different hidden sizes

The basic configuration is as table 4.

batch size	4/8
context length	512
maximum sequence length	1024
precision	fp16

Table 4: Basic configuration for performance with different hidden units

Figure 8 and Figure 9 show the Speedup compared to fairseq and Faster Transformer(v4.0), respectively.

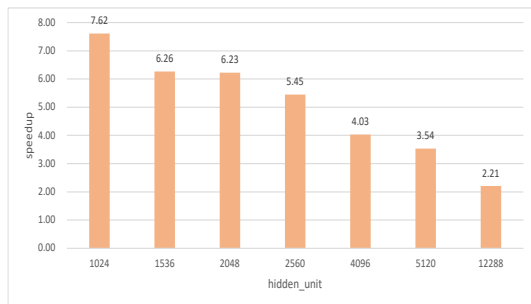

Figure 8: SpeedUp with different hidden sizes on A100 compared to Fairseq

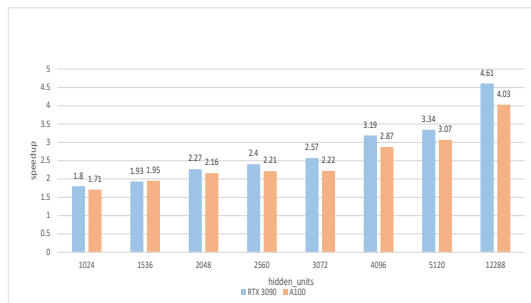

Figure 9: SpeedUp with different hidden sizes compared to Faster Transformer(v4.0)

Although the proportion of matrix multiplication increases with the model size, EET can still deliver significant speedups at large model sizes with its scaling Thread-block-folding technique.

5.2 Bert layer on 2080ti

We tested the performance of inference for Bert-base layer using EET on 2080ti, compared to Faster Transformer. Note that the padded tokens take up half of the total tokens.

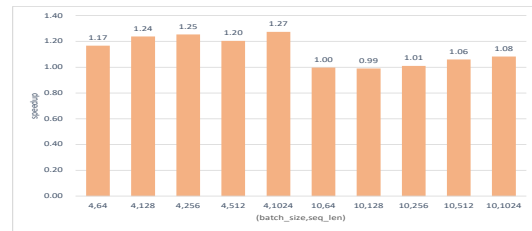

Figure 10: Performance speedup for Bert layer on 2080ti compared to FT

Deprecation of sequence mask calculation brings 1-1.27x speedup compared to Faster Transformer.

6 Conclusion

In this paper, we propose a comprehensive bunch of optimization techniques for transformer layer inference acceleration exploiting both algorithmic features and GPU hardware features. These techniques are all packed in the EET, a library dedicated to inference acceleration for large transformer-based models and long input lengths. EET has a 1.5-4.5x speedup for the GPT-2 layer and a 1.0-1.27x speedup for the Bert layer compared to Faster Transformer. We have open sourced EET on Github. We will continue to improve and keep it up-to-date.

References

- Alexei Baevski, Wei-Ning Hsu, Alexis Conneau, and Michael Auli. 2021. Unsupervised speech recognition. *arXiv preprint arXiv:2105.11084*.
- Alexei Baevski, Henry Zhou, Abdelrahman Mohamed, and Michael Auli. 2020. wav2vec 2.0: A framework for self-supervised learning of speech representations. *arXiv preprint arXiv:2006.11477*.
- Tom B. Brown, Benjamin Mann, Nick Ryder, Melanie Subbiah, Jared Kaplan, Prafulla Dhariwal, Arvind Neelakantan, Pranav Shyam, Girish Sastry, Amanda Askell, Sandhini Agarwal, Ariel Herbert-Voss, Gretchen Krueger, Tom Henighan, Rewon Child, Aditya Ramesh, Daniel M. Ziegler, Jeffrey Wu, Clemens Winter, Christopher Hesse, Mark Chen, Eric Sigler, Mateusz Litwin, Scott Gray, Benjamin Chess, Jack Clark, Christopher Berner, Sam McCandlish, Alec Radford, Ilya Sutskever, and Dario Amodei. 2020. [Language models are few-shot learners](#).
- Jacob Devlin, Ming-Wei Chang, Kenton Lee, and Kristina Toutanova. 2019. [Bert: Pre-training of deep bidirectional transformers for language understanding](#).
- Alexey Dosovitskiy, Lucas Beyer, Alexander Kolesnikov, Dirk Weissenborn, Xiaohua Zhai, Thomas Unterthiner, Mostafa Dehghani, Matthias

- Minderer, Georg Heigold, Sylvain Gelly, Jakob Uszkoreit, and Neil Houlsby. 2020. [An image is worth 16x16 words: Transformers for image recognition at scale.](#)
- Geoffrey Hinton, Oriol Vinyals, and Jeff Dean. 2015. [Distilling the knowledge in a neural network.](#)
- Yifan Jiang, Shiyu Chang, and Zhangyang Wang. 2021. [Transgan: Two transformers can make one strong gan.](#)
- Jared Kaplan, Sam McCandlish, Tom Henighan, Tom B. Brown, Benjamin Chess, Rewon Child, Scott Gray, Alec Radford, Jeffrey Wu, and Dario Amodei. 2020. [Scaling laws for neural language models.](#)
- NVIDIA. 2021a. ["faster transformer"](#).
- NVIDIA. 2021b. ["tensortt"](#).
- Adam Paszke, Sam Gross, Francisco Massa, Adam Lerer, James Bradbury, Gregory Chanan, Trevor Killeen, Zeming Lin, Natalia Gimelshein, Luca Antiga, Alban Desmaison, Andreas Kopf, Edward Yang, Zachary DeVito, Martin Raison, Alykhan Tejani, Sasank Chilamkurthy, Benoit Steiner, Lu Fang, Junjie Bai, and Soumith Chintala. 2019. [Pytorch: An imperative style, high-performance deep learning library.](#) In H. Wallach, H. Larochelle, A. Beygelzimer, F. d'Alché-Buc, E. Fox, and R. Garnett, editors, *Advances in Neural Information Processing Systems 32*, pages 8024–8035. Curran Associates, Inc.
- Colin Raffel, Noam Shazeer, Adam Roberts, Katherine Lee, Sharan Narang, Michael Matena, Yanqi Zhou, Wei Li, and Peter J. Liu. 2020. [Exploring the limits of transfer learning with a unified text-to-text transformer.](#) *Journal of Machine Learning Research*, 21(140):1–67.
- ShannonAI. 2021. [Shannonai-service-streamer.](#)
- Sheng Shen, Zhen Dong, Jiayu Ye, Linjian Ma, Zhewei Yao, Amir Gholami, Michael W. Mahoney, and Kurt Keutzer. 2019. [Q-bert: Hessian based ultra low precision quantization of bert.](#)
- Ashish Vaswani, Noam Shazeer, Niki Parmar, Jakob Uszkoreit, Llion Jones, Aidan N. Gomez, Lukasz Kaiser, and Illia Polosukhin. 2017. [Attention is all you need.](#)
- Elena Voita, David Talbot, Fedor Moiseev, Rico Senrich, and Ivan Titov. 2019. [Analyzing multi-head self-attention: Specialized heads do the heavy lifting, the rest can be pruned.](#)
- Xiaohui Wang, Ying Xiong, Yang Wei, Mingxuan Wang, and Lei Li. 2021. [Lightseq: A high performance inference library for transformers.](#)
- Xiaohua Zhai, Alexander Kolesnikov, Neil Houlsby, and Lucas Beyer. 2021. [Scaling vision transformers.](#) *arXiv preprint arXiv:2106.04560*.